**MAGNETIC CONFINEMENT
SYSTEMS**

Transverse Current at the Periphery of the Startup Plasma in the AMBAL-M Device

S. Yu. Taskaev

*Budker Institute of Nuclear Physics, Siberian Division, Russian Academy of Sciences,
pr. akademika Lavrent'eva 11, Novosibirsk, 630090 Russia*

Received January 05, 1998; in final form, August 20, 1998

Abstract—In previous experiments, a substantial longitudinal electron current was observed in the startup plasma in the end system of the AMBAL-M device. In this paper, the current at the plasma periphery is studied, the processes leading to the generation of the transverse current are discussed, and the value of the transverse current in the transportation region is determined. Analysis shows that the basic conditions providing a substantial transverse ion current are the filling up of the device with a narrow annular plasma jet and the formation of a nonequilibrium profile of the radial electric field in the plasma by the electrode potential of the end gun. Mechanism for the generation of the longitudinal electric current is discussed.

1. INTRODUCTION

In the end cell of the AMBAL-M device, a hot target plasma was produced by means of a plasma gun, without any auxiliary heating [1]. It was found that the energy transfer from hot ions to electrons through Coulomb collisions cannot provide a high electron temperature (50 eV) in the end cell [1]. Electron heating can be strongly affected by the longitudinal electron current on the order of 1 kA flowing from the plasma gun. This current was observed experimentally along the entire device [2]. The Joule heating (assuming the Spitzer plasma conductivity) also does not provide the electron energy balance [1]. At present, there is no full pattern of the processes occurring in the device fitting all the measured plasma parameters. The fundamental difficulty is associated with the variety of processes and substantial change in the plasma parameters in a non-uniform magnetic field. In this paper, we consider a particular problem that can be regarded as a step toward constructing the full pattern of electron heating.

We study the closing of current in the transportation region. We assume that the current flowing through the plasma enters the end of the device, comes back through the conducting vacuum-chamber wall, and is closed in the transportation region at the plasma periphery. The radial profiles of the plasma density and the floating potential are measured by the Langmuir probes in several cross sections of the plasma column; the magnetic probe is used to measure the radial profile of the longitudinal current density. The basic classical (collisional) processes resulting in the generation of the transverse current are considered in detail.

The paper is organized as follows. After a brief description of the experimental setup, we discuss the subject of investigation and formulate the problem. Then, we discuss the processes leading to the genera-

tion of transverse current and estimate the value of the transverse current in the transportation region. Finally, the basic results are formulated.

2. BRIEF DESCRIPTION OF THE SETUP

The schematic of the experiment is shown in Fig. 1. The detailed description of the device and basic experimental results are presented in [1–3]. The plasma gun with annular cathode and anode is used [4]. The radius of the cathode is smaller than that of the anode. The gas-discharge channel rests on the cathode and is 5.5 cm in the inner diameter and 6.5 cm in the outer diameter. Magnetic field lines emerging from the cathode do not pass through the anode. None of the gun electrodes is grounded.

3. DISCUSSION OF THE PROBLEM

The problem is related to the initial inconsistency of the concept of the current closing near the gun. Figure 2 shows that, in a decreasing magnetic field, some of the magnetic field lines emerging from the anode fall on the grounded body of the solenoid, which is designed in the form of a hollow cylinder. The onset of arcs and the closing of the current can be expected in this case. Actually, traces of the cathode spots are seen on the inner surface of the cylinder. It would seem that the electron current from the grounded body of the solenoid to the anode should flow just this way (Fig. 2, curves 6). In this case, the anode potential would be positive and almost constant throughout the entire current pulse. However, the oscillograms of the gun anode potential and of the longitudinal current, which are presented in Fig. 3, do not confirm this assumption. Therefore, we believe that the main current cannot be closed through the arc discharge between the anode and adja-

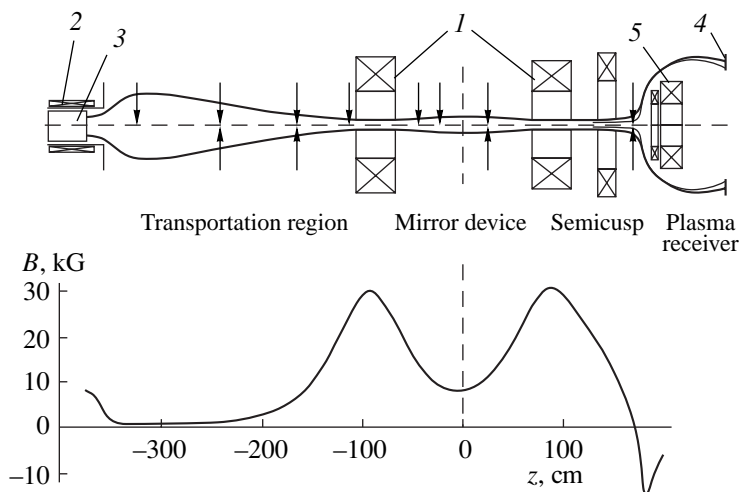

Fig. 1. End system of the AMBAL-M device and the magnetic field line emerging from the plasma gun (the magnetic field on the axis is shown below): (1) magnetic-mirror coil, (2) gun solenoid, (3) plasma gun; (4) plasma receiver, and (5) coil of the semicusp. The upper and lower arrows mark the coordinates of the cross sections in which the measurements were performed by using the Langmuir and magnetic probes, respectively. In the transportation region, the magnetic field is directed from the gun (N) to the mirror device (S).

cent grounded body of the solenoid, though (starting from 1.2 ms) this process also takes place, which is proved by the jump of the anode potential (typical of the termination of the arc discharge) at an instant of 2.75 ms.

4. FORMULATION OF THE PROBLEM

Let the plasma be magnetized and occupy a certain space in the transportation region. The boundary conditions on the gun side (left-hand side in Fig. 1) are the following: from the axis to a certain radius, the magnetic field lines are projected onto the ungrounded gun; beyond this radius, the magnetic field lines are pro-

jected onto the grounded body of the vacuum chamber. The surface separating the inner plasma, which is in contact with the insulated gun, from the outer plasma, which is in contact with the grounded wall, is of particular interest. A peculiarity of this surface is that the boundary conditions allow us to eliminate the current shorting on the conducting ends (Simon effect [5]). This surface is determined by the magnetic field line emerging from the anode at radius of 8 cm (Fig. 2, curve 7). Let us consider the processes leading to particle transport across this surface. This transport determines the longitudinal transport from the inner space across the right-hand boundary (entrance to the magnetic mirror device).

As is known, the plasma density decreases outward from this separating surface ($\partial n/\partial r < 0$) and the electric field is also directed outward ($E_r > 0$). These assumptions (which are based on the experimental data) would suffice to describe the particle transport.

We do not consider the behavior of the current ahead of and beyond this surface. The presence of the conducting ends (the gun or the grounded vacuum chamber) makes the problem rather difficult to be solved quantitatively, though there is a simple qualitative solution to the problem (Simon effect). We restrict ourselves to considering the transverse current only in the transportation region, because the measurements carried out in the magnetic mirror device reveal no reverse longitudinal electron current at the plasma periphery. This shows also that the current does not close on the opposite end. Here, we use the hydrodynamic approach; this is justified, because, in a fairly large and the most important region, the mean free paths of particles are less than the characteristic size of the system

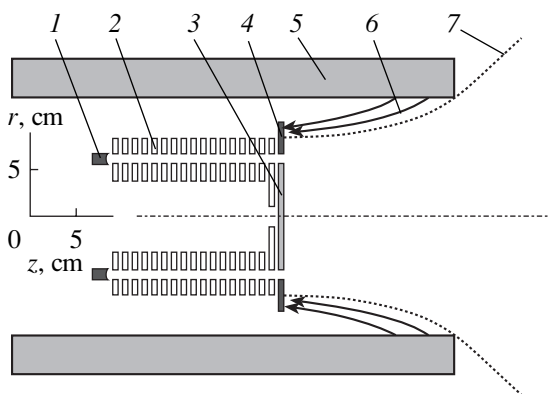

Fig. 2. The region near the plasma gun: (1) cathode, (2) insulated diaphragms, (3) inner washer, (4) anode, (5) grounded body of the solenoid, (6) possible lines of the longitudinal electron current, and (7) bounding magnetic field line.

and we are concerned with the parameters averaged over sufficiently large time interval.

5. CONSIDERATION OF THE PROCESSES LEADING TO THE TRANSVERSE CURRENT

We consider a magnetized plasma consisting of electrons and protons. The plasma is assumed to be nonuniform in the direction perpendicular to the uniform magnetic field. Let the plasma density gradient be antiparallel to the x -axis: $\partial n/\partial x < 0$. Due to the ion-ion Coulomb collisions, the ions are scattered by an angle of order unity for the characteristic collision time $\tau_{ii} =$

$$\frac{3\sqrt{MT_i}^{3/2}}{4\sqrt{\pi}\lambda e^4 Z^4 n}$$

(see, e.g., [6]), and, correspondingly, the guiding centers of ions shift in the plane (xy) (the y -axis is perpendicular to both the x -axis and the magnetic field) at a distance on the order of the ion Larmor radius ρ_i . Along the x -axis, these centers shift at the distance $\rho_i/\sqrt{2}$ to the right and to the left with equal probabilities. One half of the particles from the layer extended from $x_0 - \rho_i/\sqrt{2}$ to x_0 will pass through the plane $x = x_0$ over a time τ_{ii} in the positive direction (from the left to the right). The unidirectional current from the left is

$$j_+ = \frac{1}{2} en_- \frac{\rho_i}{\sqrt{2}} \frac{1}{\tau_{ii-}}$$

where n_- and τ_{ii-} are the plasma density and ion collision time averaged over the above layer. Since the currents directed to the left and to the right are not balanced, there is a nonzero net current $j = j_+ - j_-$ equal to

$$j = \frac{1}{2} e \frac{\rho_i}{\sqrt{2}} \left(\frac{n_-}{\tau_{ii-}} - \frac{n_+}{\tau_{ii+}} \right) = \frac{e\rho_i(n_-^2 - n_+^2)}{2^{3/2} A} = -\frac{1}{2} \frac{e\rho_i^2}{\tau_{ii}(x_0)} \frac{\partial n}{\partial x},$$

where A is a constant in the relation $\tau_{ii} = A/n$. Thus, the current is described by Fick's law, $j = -D\nabla n$, with the coefficient $D = e\rho_i^2/2\tau_{ii}$ depending on the density. The ion-ion collisions in a narrow plasma jet lead to the jet spreading and, consequently, to the generation of the transverse ion current. This is illustrated by a sketch presented in Fig. 4. Let us consider a narrow annular plasma jet in a magnetic field. Let two jet ions be located at the same radius but at different positions in azimuth. If the ion velocities turn at an angle of 90° due to collision, the centers of the Larmor circles of these two ions shift in the radial direction at a distance of the Larmor radius but in opposite directions: one ion shifts inward, and another shifts outward; i.e., both these ions will go outside the jet. Their center of mass stays at the same radius, but the jet becomes wider.

It is well known that the transverse ion current can be balanced out by the gradient drift and/or the radial

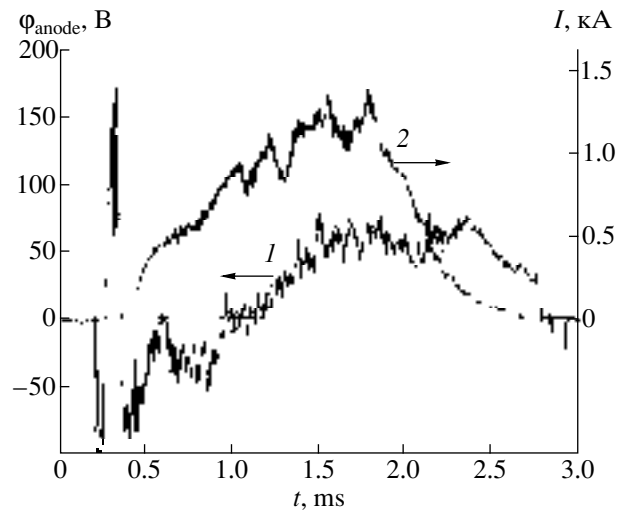

Fig. 3. Oscillograms of (1) the anode potential of the gun and (2) the longitudinal current in the magnetic mirror device measured at a radius of 11 cm by the magnetic probe.

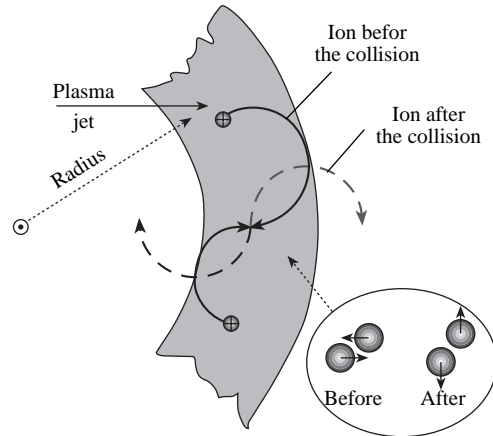

Fig. 4. The spreading of the annular jet due to the ion-ion collisions. Magnetic field is directed perpendicular to the plane of the figure.

electric field (see [7]). In order to check whether the balance really occurs [7], it is necessary to pass over to the rotating coordinate system: in the case of the gradient drift, this system must rotate counterclockwise (if one looks from the gun side), and, in the case of the radial electric field, this system must rotate clockwise. Acting together, these mechanisms amplify the transverse current rather than provide the balance of ion fluxes.

There are some analogs of the phenomena described above. For example, the electron mobility along the magnetic field lines is higher than the ion mobility; therefore, to confine the electrons, a positive potential (with respect to the throat) is established in the mag-

netic mirror. In contrast, the ions are more mobile in the transverse direction; thus, to confine them, a negative radial electric field must be established. Under our conditions, the radial electric field is positive, which assists the outward transverse ions flux.

Note that previously, when we used the inner washer of the gun (see Fig. 2, position 3) as the anode instead of the anode electrode itself, a negative electric field at the plasma periphery was established. In that case, the measured longitudinal electron current decreases by one order of magnitude compared to that obtained with the conventional connection of the plasma-gun electrodes; this effect can be explained by a decrease in the transverse ion current.

The problem of the transverse current and transverse conductivity in a strong magnetic field ($\omega_c \tau \gg 1$, where ω_c is the cyclotron frequency) is rather complicated. This problem has been thoroughly studied (see, e.g., [5, 8, 9]). To obtain particular results, the generalized Ohm's law in various forms was used [7, 10, 11].

Let us consider the generalized Ohm's law in the form presented in [10]:

$$\mathbf{E} + \frac{1}{c}[\mathbf{V} \times \mathbf{B}] = \frac{\mathbf{j}}{\sigma} + \frac{1}{enc}[\mathbf{j} \times \mathbf{B}] - \frac{1}{en} \text{grad} p_e.$$

where $\mathbf{V} = (Mv_i + mv_e)/(M + m)$ is the plasma hydrodynamic velocity.

By assuming $j = 0$, we obtain that the radial electric field leads to the azimuthal rotation of a uniform plasma. This particular solution corresponds to the case when we consider an infinitely long plasma column and the longitudinal loss can be neglected, or when the longitudinal losses are ambipolar.

Another particular solution corresponds to the case when the Hall currents are forbidden (see [7, 11]). In order to maintain the current across the magnetic field, the Hall electric field perpendicular to the external field arises. This electric field balances out the Lorentz force, acting on the charged particles. As a result, the normal transverse conductivity $j_{\perp} = \sigma_{\perp} E_{\perp}$ (where $\sigma_{\perp} \approx \sigma_{\parallel}/2$) takes place. In a sense, we can say that the magnetic field has no effect on the plasma conductivity.

However, generally, when the ambipolarity condition is not imposed on the longitudinal losses and no conditions are imposed on the current component perpendicular to the external field E_{\perp} (Hall current), the

conductivity current $j_{\perp} = \frac{\sigma_{\perp}}{1 + (\omega_{ce} \tau_e)^2} E_{\perp}$ flows along

the applied transverse electric field E_{\perp} ; this current is highly suppressed by a strong magnetic field. It is this situation that is typical of our experiment, because neither the longitudinal current (due to the plasma contact with the end of the conducting vacuum chamber) nor the Hall current (due to the cylindrical shape of the plasma) are forbidden.

Now, we draw attention to a possible increase in the transverse current associated with the plasma turbulence. The inhomogeneity of the plasma conductivity (the inhomogeneity of the classical conductivity can be due to the inhomogeneity of the electron temperature) suppresses the Hall current. Even small inhomogeneity of a strongly magnetized plasma can lead to a substantial increase in the current along the transverse electric field. This effect was discussed in [8] and then studied by Kadomtsev [12], who considered the turbulent plasma and showed that, if the average azimuthal electric field is equal to zero and, for simplicity, the conductivity as a function of density is assumed to be σ/n , the transverse current in the case of high-frequency ($\omega > \omega_{ci}$) isotropic oscillations increases by a factor of about $\omega_{ce} \tau_e$ (in the case of low-frequency oscillations, the increase is lower) due to the additional term $\langle en'E' \rangle$. Note that the longitudinal current remains almost unchanged.

This mechanism requires a closer inspection. Note that the increase in the transverse plasma diffusion due to the onset of electrostatic oscillations in plasma was observed in [13]. In this paper, we propose the following qualitative explanation of this mechanism. Let the azimuthal electric field be harmonically modulated in the azimuthal direction, the averaged value being equal to zero. Then, in the regions where the field direction coincides with the direction of the Hall field, the normal conductivity can take place; in the other regions, in contrast, the conductivity can vanish almost completely. As a result, the total transverse current will increase by a factor of $(\omega_{ce} \tau_e)^2/2$ compared to the field without modulation.

We have also considered some other processes resulting in the transverse current. The collisions with neutrals were found to contribute insignificantly, because the density of the gas (for the most part, hydrogen) at the separating surface is much less than the plasma density. Another process, which we will consider in more detail, also proves to be inessential. Near the separating surface, the plasma potential is positive, and it is the positively charged plasma that will leave the inner region due to both ambipolar diffusion and the onset of balloon perturbations. The probe located at the plasma periphery shows the floating-up of balloon perturbations (Fig. 6 in [2]). The frequency of these oscillations coincides with the frequency of the Kelvin-Helmholtz instability, which initiates the floating-up. By using the integral form of Poisson's equation, $\oint_S E_n ds = 4\pi \int_V \rho dV$, from the measured radial profile of the potential (Fig. 11 in [1]), we find the charge density. This density corresponds to the excess density of singly charged particles on the order of $2 \times 10^5 \text{ cm}^{-3}$, which is much less than the plasma density. The ambipolar diffusion in the transportation region is assumed to cause a transverse plasma flow equivalent to kiloampere current. Since the plasma is charged, this diffusion

is accompanied by an electric current, which however is negligibly small (about 10^{-5} A).

6. EVALUATION OF THE TRANSVERSE CURRENT IN THE TRANSPORTATION REGION

In order to determine the transverse current accurately, it is necessary to carry out numerical calculations and refine the above expression for the current. As will be shown below, it is also necessary to measure more accurately the parameters of a nonuniform plasma in a large volume. Here, we restrict ourselves to the evaluation of the outward transverse ion current across the surface bounding the transportation region. This current is the sum of the current I_{\perp}^i , resulting from the ion-ion collisions in the nonuniform plasma, and the current I_{\perp}^E , caused by the radial electric field at a highly suppressed transverse conductivity. The assumption of a strong magnetic field is justified, because, under our experimental conditions, $\omega_{ci}\tau_{ii} > 150$ and $\omega_{ce}\tau_e > 400$; i.e., both the ions and electrons are magnetized. In the presence of an azimuthal uniformity, the transverse current can be written in the form

$$I_{\perp}^i = \int \frac{1}{2} \frac{e\rho_i^2}{\tau_{ii}} \frac{\partial n}{\partial r} 2\pi r dz \propto S \frac{e v_{Ti}^2}{2\omega_{ci}^2 \tau_{ii}} \frac{n}{L_{\perp}},$$

$$I_{\perp}^E = \int \frac{\sigma_{\perp} E_{\perp}}{(\omega_{ce} \tau_e)^2} 2\pi r dz \propto S \frac{e^2 n}{m\omega_{ce}^2 \tau_e} E.$$

First, we will estimate the value of I_{\perp}^i . The major contribution to this current comes from the region of a low magnetic field. Over the distance $\Delta z = 100$ cm, the magnetic field value lies in the interval from 440 G to 1 kG. The transverse ion temperature in this region is $T_i = 50$ eV, so that the ion Larmor radius is $\rho_i = 1-2$ cm. For a typical plasma density of $n = 10^{13}$ cm $^{-3}$, the ion-ion collision time is $\tau_{ii} \approx 30$ μ s. The radius of the separating surface is $r = 20-30$ cm, and the transverse scale length of the density variation is $L_{\perp} = r/4$ (see Fig. 16 in [1]). By substituting these values into the above expression, we find the transverse current across the separating surface in the low-field region to be $I_{\perp}^i \approx 200$ A. By using the plasma parameters from experiment [1], the total transverse current over the distance $\Delta z = 285$ cm was found to be 280 A.

A high value of the current is mainly due to both a fairly large area of the bounding surface (3.7×10^4 cm 2) and relatively large ratio of the Larmor radius to the scale length of the plasma density inhomogeneity, $\rho_i/L_{\perp} \sim 1/4$. The direct influence of the ion temperature is small, $j \propto T_i^{-1/2}$. We note that there is one more reason for the large transverse current. To show this, we will consider a crude model in which the transportation

region is regarded as a large magnetic mirror. The gun generates a plasma flow (I_{pl}) entering this region. Let us denote the plasma lifetime in this mirror device by τ^* . Then, specifying the plasma density as $n = I_{pl}\tau^*/er^2L_{\parallel}$ and taking into account that $\tau_{ii} \propto n^{-1}$, we arrive at the following expression for the transverse current: $I_{\perp}^i \propto S(n^2/B^2L_{\perp}) \propto I_{pl}^2 \tau^{*2} (r/L_{\parallel}L_{\perp})$. The last factor shows that the large area of the bounding surface plays an important role due to both a relatively weak (however, strong enough for the plasma to be magnetized) magnetic field and the use of an initially narrow annular plasma jet. However, the transverse current depends most strongly on the lifetime τ^* , which enters the above expression quadratically. Let us elucidate this dependence. The gun is located behind the magnetic mirror, and the transportation region is used to transport the plasma jet to the main magnetic mirror device. In our previous experiments, all the plasma generated by the gun was transported to the mirror device in the regime of a collisional subsonic flow [14]. In this regime, the plasma lifetime in the transportation region is equal to the time required for the plasma to flow across this region with the ion velocity. The measured longitudinal current was negligibly small. Here, we use another regime in which the transport of the plasma as a whole is absent. Due to a steeper magnetic field (which leads to an increase in the volume occupied by plasma) and "transverse" ion heating (i.e., an increase in the transverse ion energy [15]), the plasma flow is collisionless in front of the magnetic mirror and a substantial fraction of the flow (about 0.9-0.95) is reflected from the throat. This leads to a decrease in the plasma density in the throat and the formation of the desired thermal barrier [16]. The plasma lifetime in the transportation region increases substantially compared to the case of the transportation of a collisional jet; as a result, the transverse current increases. As the longitudinal confinement of plasma is improved, the transverse loss comes into play.

Now, we determine the current I_{\perp}^E caused by the radial electric field. By dividing the above expression for I_{\perp}^E by I_{\perp}^i and using the results of [7], we obtain the

ratio between these two currents to be $\frac{I_{\perp}^E}{I_{\perp}^i} =$

$$\frac{eL_{\perp}E\omega_{ci}\tau_{ii}}{T_i\omega_{ce}\tau_e} = \frac{eL_{\perp}E}{T_i} \sqrt{2} \sqrt{\frac{m}{M}} \left(\frac{T_i}{T_e}\right)^{3/2},$$

which is equal to the product of the ratio of the potential difference across the gradient scale length to the ion temperature and the "magnetization ratio" (equal to approximately 0.37 due to a relatively high ion temperature, $T_i/T_e \approx 5$). In the cross section $z = 325$ cm, the ratio of currents is approximately 0.7 at $E_{\perp} = 15$ V/cm. From the above expression for the current ratio, it is seen that this ratio

varies only slightly over the transportation region. The integral (over the entire separating surface) current due to the transverse conductivity is equal to 200 A. A similar value is also obtained from other considerations. Writing out the expression for the ratio of the transverse current I_{\perp} in the transportation region to the longitudinal current I_{\parallel} in the throat of the mirror (which is on the order of 1 kA) and substituting the typical values for the quantities entering this expression (the most uncertain term here is $\omega_{ce}\tau_e$), we obtain

$$\frac{I_{\perp}}{I_{\parallel}} = \frac{\sigma_{\perp} E_{\perp} S_{\perp}}{\sigma_{\parallel} E_{\parallel} S_{\parallel}} \frac{1}{(\omega_{ce}\tau_e)^2}$$

$$\sim \frac{1}{1.96 \times 1.5^{3/2} \cdot 0.5} \frac{25 \cdot 37000}{10} \frac{1}{(700)^2} = \frac{1}{10}.$$

Thus, the classical (collisional) mechanisms, namely ion–ion collisions leading to the spreading of a narrow annular plasma jet and the transverse current in the radial electric field at a substantially suppressed conductivity, produce a total ion current of approximately 500 A flowing outward across the separating surface. Taking into account the evaluation accuracy, the possible increase in the current due to conductivity fluctuations, and an additional contribution (starting from 1.2 ms) of the longitudinal current from the prominent grounded body of the solenoid to the gun anode, we can conclude that the mechanisms for closing the kiloampere current are determined.

In conclusion, we discuss the pattern of currents. A longitudinal electron current on the order of 1 kA flows out from the transportation region into the magnetic mirror device through the 10 cm² aperture in the throat [1]. Since the inner part of the plasma is projected onto the insulated gun, where the current is absent, the transverse ion current of the same value should flow out across the surface separating the inner and outer (peripheral) regions in order to maintain the plasma quasineutrality. Further, this current can flow both along and across the magnetic field lines.

Two of the specific features of the magnetic mirror device (which are listed in [17]) manifest themselves in these experiments. First, the plasma behavior is well described by classical phenomena, i.e., by collisional processes. Second, the possibility of controlling over the radial profile of the potential allows us to vary the plasma confinement time and the direction in which the ions escape from the system.

7. GENERATION OF THE LONGITUDINAL CURRENT

Since the current-closing processes are determined, we can improve the model for the longitudinal current. The plasma is produced by an arc source (gun) with an annular gas-discharge channel in the axial magnetic field. The discharge current is approximately 12 kA. Since the plasma is magnetized there and the annular

cathode is magnetically insulated from the anode, a fraction of the discharge current (approximately 2 kA) flows through the plasma jet. The current in the form of loops, which are observed in the transportation region, is due to the transverse plasma conductivity. As was stated above, one more element is present in the current circuit between the cathode and the anode. Due to the processes listed above, a transverse ion current flows across the surface separating the plasma region projected along the magnetic field lines onto the insulated gun anode from the plasma region projected onto the grounded vacuum chamber. This current is closed by the electron current flowing along the magnetic field lines from the cathode to the grounded end. Thus, the observed longitudinal electron current is a fraction of the discharge current. Its value and behavior are also indirectly governed by the other components of the discharge current. This can be explained as follows: since the ions leave the transportation region across the magnetic field, the electrons must go away along the magnetic field lines in order to maintain the plasma quasineutrality. It may appear that the gun discharge itself is of little or no importance here. However, in fact, the potential of the plasma-gun electrodes create the radial electric field, which facilitates the outward ion motion. Of course, due to processes discussed above, the longitudinal electron current can also occur in the absence of the gun discharge (at least, in the plasma-decay stage). The problem is in the value of the current. If the gun electrodes do not maintain a nonequilibrium radial profile of the potential, the transverse ion current and, correspondingly, the longitudinal electron current are substantially less.

8. CONCLUSIONS

We have studied the transverse current at the periphery of the startup plasma in the AMBAL-M device. It is found that the experimentally observed substantial longitudinal electron current is a fraction of the discharge current of the plasma gun. It is shown that the following processes provide closing of the current at the plasma periphery:

- (i) ion–ion collisions leading to a spreading of the narrow annular plasma jet;
- (ii) the transverse current caused by the positive radial electric field in the presence of the electron–ion collisions; this current, which is substantially suppressed by the magnetic field, may increase due to the fluctuations of the plasma conductivity; and
- (iii) the longitudinal current from the prominent part of the grounded solenoid body to the gun anode.

The following factors are found to be responsible for the large transverse current at the plasma periphery: the improved longitudinal plasma confinement in the transportation region, specific magnetic and vacuum features of the device (the large plasma volume and the conducting vacuum chamber), and the method for

plasma production (the generation of the initially narrow annular dense-plasma jet by the insulated end gun, and the formation of a nonequilibrium positive radial electric field in the plasma by the potential of the gun electrodes).

REFERENCES

1. Akhmetov, T.D., Belkin, V.S., Bender, E.D., *et al.*, *Fiz. Plazmy*, 1997, vol. 23, p. 988 [*Plasma Phys. Rep.* (Engl. transl.), vol. 23, p. 911].
2. Akhmetov, T.D., Davydenko, V.I., Kabantsev, A.A., *et al.*, *Fiz. Plazmy*, 1998, vol. 24, p. 1065 [*Plasma Phys. Rep.* (Engl. transl.), vol. 24, p. 995].
3. Taskaev, S.Yu., *Preprint of Budker Inst. of Nuclear Physics, Siberian Division, Russ. Acad. Sci.*, Novosibirsk, 1995, no. 95-92.
4. Dimov, G.I., Ivanov, A.A., and Roslyakov, G.V., *Fiz. Plazmy*, 1982, vol. 8, p. 970 [*Sov. J. Plasma Phys.* (Engl. transl.), vol. 8, p. 546].
5. Simon, A., *Phys. Rev.*, 1956, vol. 100, p. 1557.
6. Hinton, F., *Osnovy fiziki plazmy* (Basic Plasma Physics), Galeev, A.A. and Sudan, R., Eds., Moscow: Energoatomizdat, 1983, vol. 1, p. 152.
7. Braginskii, S.I., *Reviews of Plasma Physics*, Leontovich, M.A., Ed., New York: Consultants Bureau, 1965, vol. 1, p. 205.
8. Yoshikawa, S. and Rose, D.J., *Phys. Fluids*, 1962, vol. 5, p. 334.
9. Chen, F., *Introduction to Plasma Physics* New York: Plenum, 1984.
10. Artsimovich, L.A. and Sagdeev, R.Z., *Fizika plazmy dlya fizikov* (Plasma Physics for Physicists), Moscow: Atomizdat, 1979.
11. Kolesnikov, P.M., *Elektrodinamicheskoe Uskorenie Plazmy* (Electrodynamical Acceleration of Plasma), Moscow: Atomizdat, 1971.
12. Kadomtsev, B.B., *Voprosy teorii plazmy* (Reviews of Plasma Physics), Leontovich, M.A., Ed., Moscow: Gosatomizdat, 1964, vol. 4, p. 314.
13. Kabantsev, A.A. and Taskaev, S.Yu., *Fiz. Plazmy*, 1990, vol. 16, p. 700 [*Sov. J. Plasma Phys.* (Engl. transl.), vol. 16, p. 406].
14. Kabantsev, A.A., Sokolov, V.G., and Taskaev, S.Yu., *Fiz. Plazmy*, 1995, vol. 21, p. 775 [*Plasma Phys. Rep.* (Engl. transl.), vol. 21, p. 735].
15. Kabantsev, A.A. and Taskaev, S.Yu., *Fiz. Plazmy*, 1992, vol. 18, p. 635 [*Sov. J. Plasma Phys.* (Engl. transl.), vol. 18, p. 331].
16. Dimov, G.I., Kabantsev, A.A., Kuz'min, S.V., *et al.*, *Fiz. Plazmy*, 1993, vol. 19, p. 350 [*Sov. J. Plasma Phys.* (Engl. transl.), vol. 19, p. 180].
17. Post, R.F., *Fiz. Plazmy*, 1997, vol. 23, p. 816 [*Plasma Phys. Rep.* (Engl. transl.), vol. 23, p. 756].

Translated by A. D. Smirnova

SPELL:
shits